

Fleetguard®

FH232 Series Diesel Pro® Diesel Fuel Filtration System

Filter Element

Quick change, easy disposal

Self Priming Port

Just spin off the cap, pour in fuel and restart the engine with clean, filtered fuel

Clear Cover

See when NOT to change filters

Seeing is Believing®

Check Valve

Internal, easy to service

Aluminum Construction

Drain Valve

Clean operation



Eliminate Unnecessary Changes & Maintenance

- See when NOT to change your filter
- Extend filter change intervals
- Clear cover provides instant visual indication of filter life
- See fuel condition and flow

Five Minute Filter Change

- Dry Filter Changes: Drain fuel below collar and replace
- No Fuel Spills: Removing standard filters full of fuel can be messy and hazardous
- Back-Up Emergency Provision: Diesel Pro also accepts standard spin-on filters in an emergency

Fuel Warmer Options

- 12 or 24 V, 150 W filter heater
- 120 V overnight heater
- Fluid heater option

Featuring StrataPore™

- Maximum strength and durability
- Improved efficiency and longer life
- The best Fuel / Water Separation available
- Reduced restriction to flow
- Supports extended service intervals
- Maintains its Fuel / Water Separation efficiency over time

Suggested Markets

- Mining
- Construction
- Agriculture
- Medium Duty On-Highway
- Oil and Gas
- Power Generation

All-In-One Fuel Filter, Water Separator and Fuel Heater

Fleetguard Family of Brands



Housings Available

Housing Part Number	Filter Element	Pre-Heater 1	Pre-Heater 2	Fluid Heat	WIF	Fuel Flow
FH23200	FS19730	N/A	N/A	N/A	N/A	In Right / Out Left
FH23201	FS19730	24 VDC	N/A	N/A	N/A	In Right / Out Left
FH23202	FS19730	12 VDC	N/A	N/A	N/A	In Right / Out Left

Dimensions

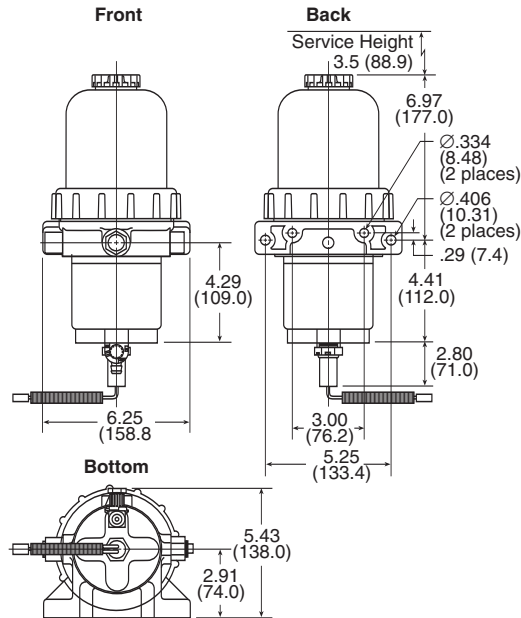

All dimensions are in inches (millimeters)

Typical Installation

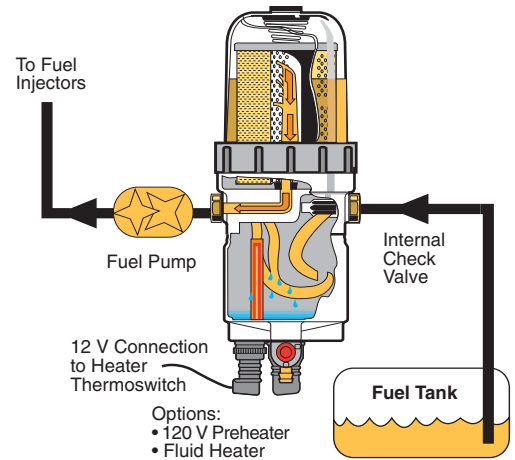

Specifications

Height Overall	14.0" (356.6 mm)
Depth Overall	5.90" (150 mm)
Width, Max.	6.25" (159 mm)
Mount Bracket Centers or Rear Mount Centers	5.25" (133.4 mm) 3.0" (76.2 mm)
Weight (Dry)	4.94 lbs (2.24 kg)
Fuel Capacity (w/o filter)	15.2 oz (0.45 L)
Fuel Connections (Inlet)	3/8" NPTF
Fuel Connection (Outlet)	3/8" NPTF
Optional Fuel Outlet	3/4"-16 O-Ring Boss
Oper. Fuel Flow Rate	60 gph (230 lph)
Recommended Application	Light and Medium Duty Engines
Water Trap Capacity	11.0 fl oz (0.32 L)
Filter Replacement	FS19730*
Filter Service Clearance	Min. 3.5" (88.9 mm)
Mounting Bracket	Cast in Head
Electrical Heater	12 VDC, 150 W, 13 A ± 3 A 24 VDC, 150 W, 6.5 A ± 2 A 120 VAC, 37 W, 3 A ± .05 A
Fluid Heater Optional	

* Other filter options at different Micron Ratings are available.
 Specifications subject to change without notice.

Visit www.fleetguard.com for:

- More information on the Diesel Pro® 232 Series:

LT15312 - Diesel Pro 232
 Installation Instructions

TB04/04-1 - Diesel Pro 232
 Technical Bulletin

- Information on the Fleetguard Diesel Pro® 233 Series and Fuel Pro® 230 Series Diesel Fuel Filtration Systems for other engine applications.

